

ST 3000 FF Fieldbus Pressure Transmitters



34-ST-03-72
03/00

Overview

Introduction

The **ST 3000 Fieldbus Transmitter** is designed as an enhancement to smart or analog transmitters and may use the existing transmitter signal lines for power and communication for ease of field upgrade. In addition to features currently offered with other smart transmitters, the following key features are now available with the ST 3000 Fieldbus transmitter:

- Fieldbus Foundation™ registration
- Backup Link Active Scheduler (LAS).
- Analog Input and PID Control Function Blocks.
- Custom polynomial for level and flow linearization.
- “Electronic Nameplate” data and download via the bus.

ST 3000 Fieldbus transmitters accurately measure differential, gauge, or absolute pressure. A piezoresistive sensor is combined with state-of-the-art electronics to provide a digital output signal proportional to the measured variable.

Accuracy is enhanced by compensating the output signal for the effects of ambient temperature and static pressure changes and for device non-linearities. Typical process control applications include measuring the fluid flow rate through a pipe, or measuring the level of a liquid in a tank.

Communication through a fieldbus host system provides labor saving capabilities such as remote transmitter adjustments and diagnostics. An operator can adjust and display operating information, re-range the transmitter without applied calibration pressures, initiate diagnostic tests, and read the input pressure and output signal, all without leaving the control room.

This, coupled with the transmitter's wide span adjustment, means that the ST 3000 Fieldbus transmitter is extremely adaptable to a variety of applications, and it can easily be adjusted to meet changing requirements.

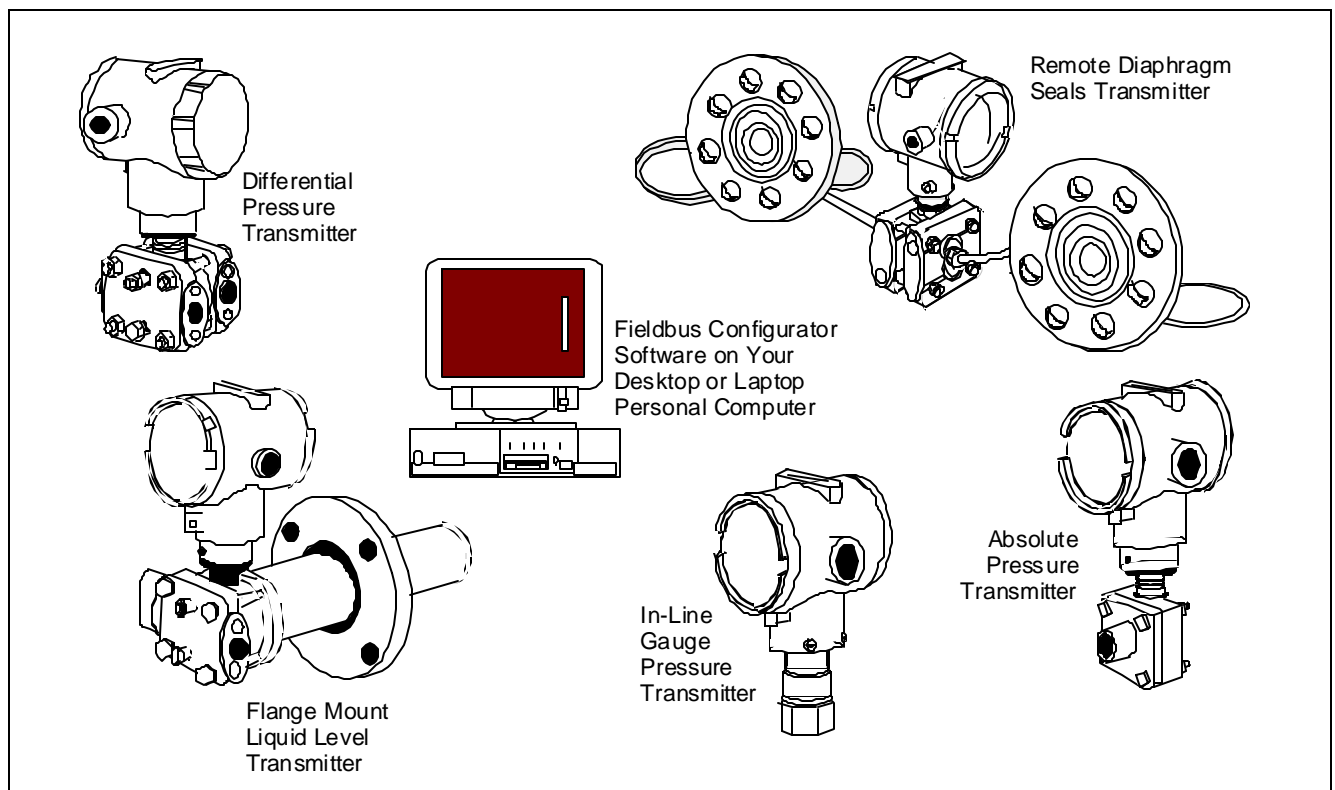

Figure 1 ¾ Typical ST 3000 Fieldbus Transmitter Types and Fieldbus Configurator

The ST 3000 Fieldbus Family

As shown in Figures 1 and 2, the ST 3000 Fieldbus family consists of a full line of pressure transmitters. Model selection is simplified because the ST 3000 Fieldbus transmitter provides a versatile range of span adjustments as listed in Table 1, which result in a turndown ratio as high as 400 to 1.

And, no matter what model or type of transmitter selected, the same configuration tool communicates with all of them.

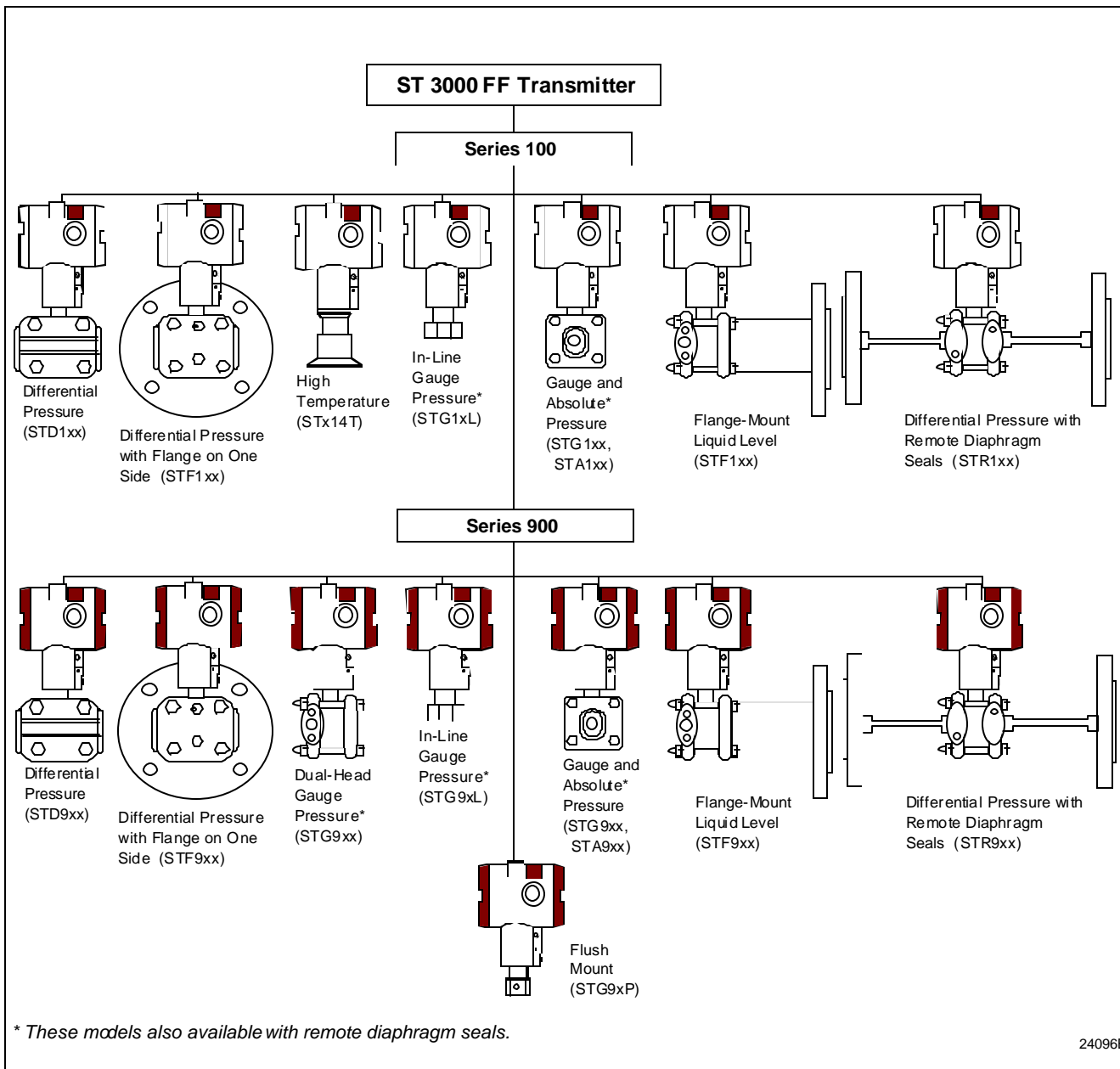

Figure 2 ¾ ST 3000 Fieldbus Transmitter Family Tree

Table 1 ³/₄ Summary of ST 3000 Fieldbus Transmitter Family Model Number Selections

Model Number	Available Range	Minimum Span	Turndown Ratio
Differential Pressure Transmitters			
STD 110	0 to 10 inH ₂ O (0 to 25 mbar)	0.4 inH ₂ O (1 mbar)	25 to 1
STD 120	0 to 400 inH ₂ O (0 to 1000 mbar)	1 inH ₂ O (2.5 mbar)	400 to 1
STD924	0 to 400 inH ₂ O (0 to 1000 mbar)	10 inH ₂ O (25 mbar)	40 to 1
STD125	0 to 600 inH ₂ O (0 to 1500 mbar)	25 inH ₂ O (62.5 mbar)	24 to 1
STD130, STD930	0 to 100 psi (0 to 7 bar)	5 psi (0.35 bar)	20 to 1
STD170, STD974	0 to 3000 psi (0 to 210 bar)	100 psi (7 bar)	30 to 1
Gauge or Absolute Pressure Transmitters			
STG93P	0 to 100 psi (0 to 7 bar)	5 psi (0.35 bar)	20 to 1
STG14T	0 to 500 psi (0 to 35 bar)	0.9 psi (0.063 bar)	550 to 1
STG140, STG14L	0 to 500 psi (0 to 35 bar)	5 psi (0.35 bar)	100 to 1
STG944, STG94L	0 to 500 psi (0 to 35 bar)	20 psi (1.4 bar)	25 to 1
STG170, STG17L	0 to 3000 psi (0 to 210 bar)	100 psi (7 bar)	30 to 1
STG974, STG97L	0 to 3000 psi (0 to 210 bar)	300 psi (21 bar)	10 to 1
STG18L, STG180	0 to 6000 psi (0 to 415 bar)	100 psi (7 bar)	60 to 1
STG98L	0 to 6000 psi (0 to 415 bar)	500 psi (35 bar)	12 to 1
STA122, STA922	0 to 780 mmHgA (0 to 1040 mbarA)	50 mmHgA (67 mbarA)	15 to 1
STA140	0 to 500 psia (0 to 35 barA)	5 psia (0.35 barA)	100 to 1
STA940	0 to 500 psia (0 to 35 barA)	20 psia (1.4 barA)	25 to 1
Flange Mounted Differential Pressure Transmitters			
STF128, STF12F	0 to 400 inH ₂ O (0 to 1000 mbar)	10 inH ₂ O (25 mbar)	40 to 1
STF924, STF92F	0 to 400 inH ₂ O (0 to 1000 mbar)	25 inH ₂ O (62.5 mbar)	16 to 1
STF132, STF13F, STF932, STF93F	0 to 100 psi (0 to 7 bar)	5 psi (0.35 bar)	20 to 1
STF14F	0 to 600 inH ₂ O (0 to 1500 mbar)	25 inH ₂ O (62.5 mbar)	24 to 1
STF14T	0 to 500 psi (0 to 35 bar)	0.9 psi (0.063 bar)	550 to 1
Remote Seal Differential or Gauge Pressure Transmitters			
STR12D	0 to 400 inH ₂ O (0 to 1000 mbar)	10 inH ₂ O (25 mbar)	40 to 1
STR13D	0 to 100 psi (0 to 7 bar)	5 psi (0.35 bar)	20 to 1
STR93D	0 to 100 psi (0 to 7 bar)	0.9 psi (0.063 bar)	110 to 1
STR14G	0 to 500 psi (0 to 35 bar)	5 psi (0.35 bar)	100 to 1
STR94G	0 to 500 psi (0 to 35 bar)	20 psi (1.4 bar)	25 to 1
STR17G	0 to 3000 psi (0 to 210 bar)	100 psi (7 bar)	30 to 1
STR14A	0 to 500 psia (0 to 35 barA)	5 psia (0.35 barA)	100 to 1

Foundation Fieldbus Functions of the ST 3000 Fieldbus Transmitter

The **ST 3000 Fieldbus Transmitter** has been designed to fully comply with Fieldbus Foundation specifications. As such, it contains the software architecture defined in the specifications.

Code Download

The ST 3000 Fieldbus transmitter is designed to support code download over the fieldbus. This allows the user to easily update the device software without changing PROMS.

As shown in Figure 3, the ST 3000 Fieldbus transmitter contains following block objects:

- 1 Resource block
- 1 Transducer block
- 1 Analog Input (AI) function block
- 1 Proportional Integral Derivative (PID) Control function block.

Resource Block

The resource block contains data and parameters related to overall operation of the device and the Function Block Application Process (FBAP). Parameters that reside in the resource block describe the hardware-specific characteristics of the device and support device application download operations.

Transducer Block

In the ST 3000 Fieldbus transmitter, the transducer block:

- Takes sensor measurements from the signal processing software,
- Performs a linearization,
- Executes additional math functions, if selected.

The transducer block has the ability to put the measured pressure value through a fifth-order polynomial equation. See Figure 4. This processing enables it to closely approximate the volume of an irregularly shaped tank or vessel, or to compensate the flow rate for variations in Reynolds Number. The user must provide the coefficients for this equation, as the device has no knowledge of the shape of the vessel or the type of primary flow element being used.

Analog Input Block

The Analog Input (AI) function block takes the output signal from the transducer block and makes it available to other function blocks as its output. For example, the output of the AI function block may be linked as an input to the transmitter's PID Control function block.

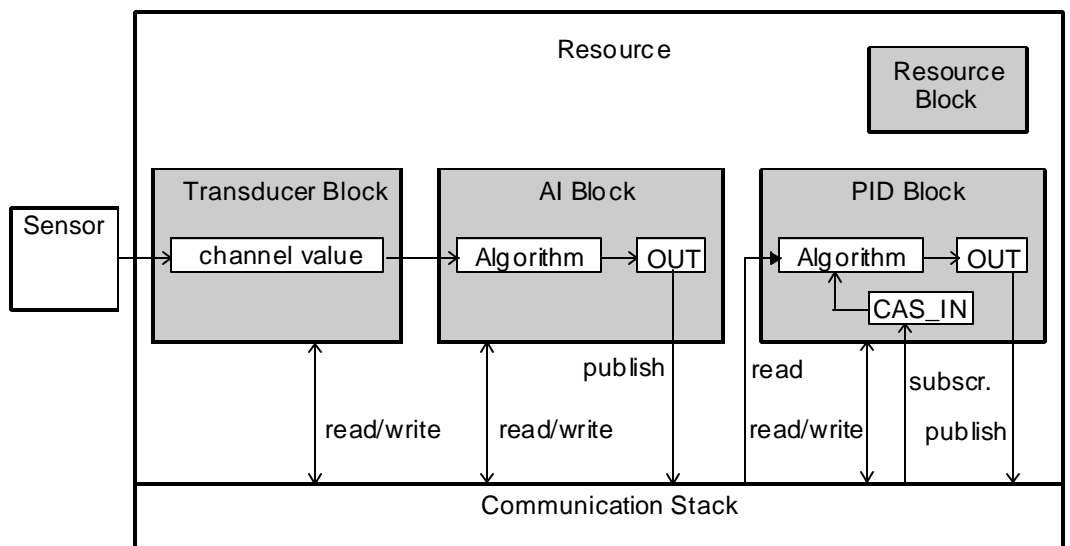

24108

NOTE: Not all parameters are shown.

Figure 3 —ST3000 Fieldbus Function Block Application Process (FBAP) Overview

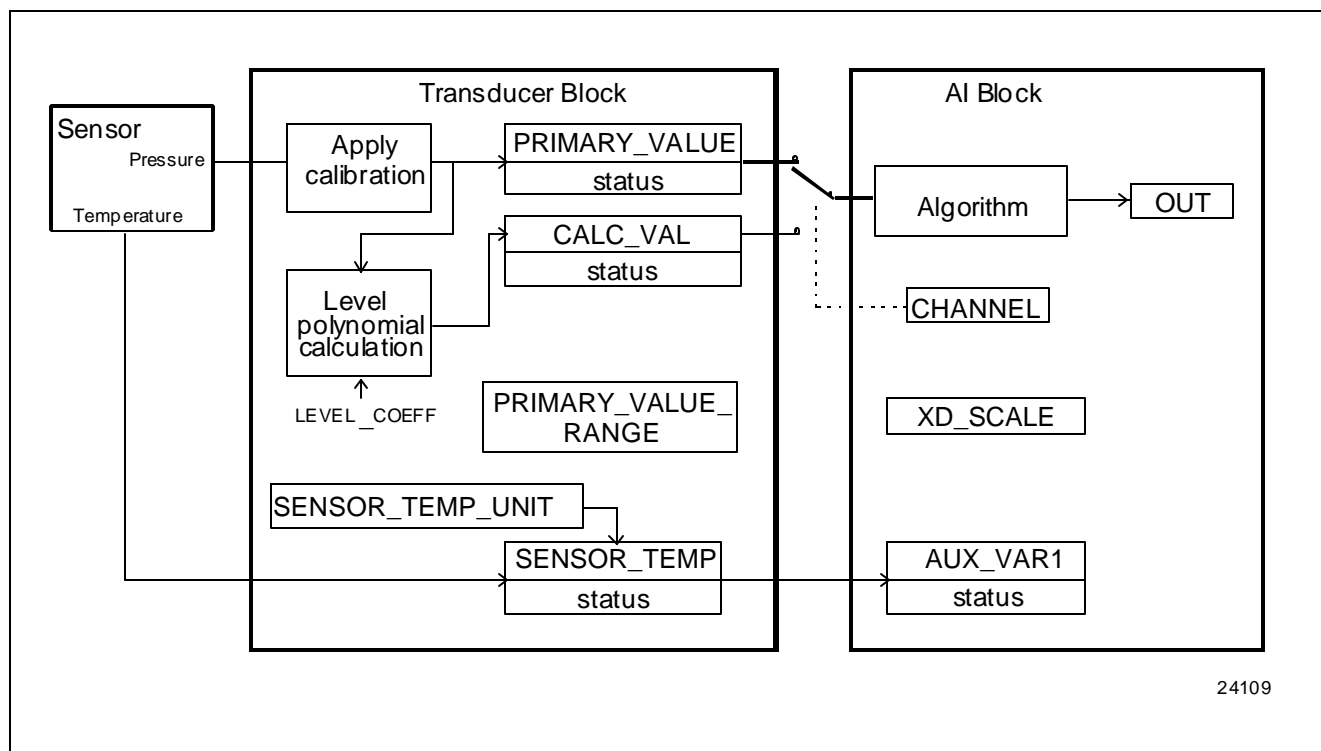

Figure 4 ¾ Transducer and Analog Input Function Block Diagram

Referring to the block diagram in Figure 4, two values from the transducer block are supplied as inputs to the AI block:

1. PRIMARY_VALUE or CALC_VAL can be selected using the CHANNEL parameter as the first input. (See Table 2.)
2. SENSOR_TEMP is supplied as the second input to the AI block.

The AI block OUT parameter value can be shown on an optional local meter display in selected engineering units (Option SM).

Table 2 —CHANNEL Parameter Description

When CHANNEL Parameter equals . . .	The Value Selected (from Transducer Block) is . . .
1	PRIMARY_VALUE, which is the direct pressure measurement, value from the sensor.
2	CALC_VAL which is the result of the Level Polynomial calculation.
Other	Error - the AI block remains in (O/S) mode.

PID Control Function Block

The PID Control function block provides you with the choice of either an Ideal (the default) or Robust PID control equation. The Ideal PID equation uses standard parameters that are defined in Fieldbus Foundation specifications. The Robust equation uses the standard fieldbus parameters plus Honeywell-defined extension parameters for PID control. A description of these parameters is given in Table 3.

The PID output is adjusted by tuning constants. Three tuning constants are used in the Ideal PID equation. The robust PID uses four tuning constants.

1. GAIN is the tuning constant of the Proportional term.
2. RESET is the tuning constant of the Integral term.
3. RATE is the tuning constant of the Derivative term. RATE is usually modified by a lag, which is set at some fixed ratio higher than the rate time, to create a rate gain. There is no lag with the rate in this implementation.
4. OUT_LAG is the fourth tuning constant used in the robust PID, it adds roll off to the output response. The action is similar to PID with rate gain.

Input to the PID block is configurable. For example, any value which is broadcast on the bus can be linked as the input to the PID.

Table 3 —Honeywell PID Parameters

Parameter Name	Description/Parameter Contents
PID_FORM	Configuration parameter specifies the IDEAL or ROBUST PID equation to be used: <ul style="list-style-type: none"> • IDEAL PID (default). Non-Interactive form of a three mode control algorithm that provides Proportional, Integral and Derivative control action. Linear and non-linear gain parameters are available. • ROBUST PID. The same as Ideal PID. Additionally, the algorithm supports a user-configurable lag filter applied to calculated output value. (See OUT_LAG parameter.) Linear and non-linear gain parameters are available.
ALGO_TYPE	Configuration parameter specifies algorithm type which can be A,B, or C: <ul style="list-style-type: none"> • Type “A” equation where Proportional, Integral and Derivative act on ERROR. • Type “B” equation where Proportional and Integral act on ERROR and Derivative acts on PV. • Type “C” equation where Integral acts on ERROR and Proportional and Derivative act on PV.
OUT_LAG	Time constant of single exponential lag filter applied to the OUT parameter (primary output). Units (in seconds). The time constant for Ideal PID lag filter is fixed at 1/16 of a second and is not configurable. The time constant is adjustable for the Robust PID.
GAIN_NLIN	Dimensionless gain factor. When the gain factor is multiplied by absolute value of the error and added to the linear GAIN, the result is a gain response that is proportional to the deviation.
GAIN_COMP	The composite gain quantity comprising both linear and non-linear gain. Read only parameter.
ERROR_ABS	Absolute value of the difference between WSP and PV. Read only parameter.
WSP	Working setpoint. This is the setpoint value after absolute and rate limits have been applied. Deviation alarms are computed on this value. Read only parameter.

Fieldbus Device Descriptions (DD)

Standardized descriptions and definitions are used to describe field devices that promote the interoperability of fieldbus devices. One of these standardized "tools" is the Device Description (DD).

A typical DD contains information about the device parameters and operation, such as:

- Attributes like coding, name, engineering unit, write protection, how to display parameters, etc.
- Maintenance, calibration and other necessary operation information.

Standard DD's for function blocks and transducer blocks are maintained by the Fieldbus Foundation. Honeywell and other manufacturers use these DD's to describe the standard features of their fieldbus devices, as well as providing device-specific extensions that describe custom features unique to that particular device.

Standard Features of the ST 3000 Transmitter

In addition to the comprehensive fieldbus functions, the ST 3000 Fieldbus transmitter also provides these features and benefits:

Silicon Sensor and Meter Body

The ST 3000 Fieldbus transmitter uses the extremely reliable piezoresistive strain gauge. The sensor is an electric wheatstone bridge circuit ion-implanted onto a silicon chip. The sensor is sealed in the meter body from the process by metal diaphragms and silicone fill fluid. This integrated sensor provides three signals (process pressure, sensor temperature, and static pressure) to an interface circuit. The three signals are converted to digital signals for input to the microprocessor.

Every meter body is characterized in the factory for the effects of changing combinations of differential pressure, static pressure and temperature. This information is stored in a characterization PROM (programmable read only memory) located in the meter body of the transmitter. These factors are accessed by the microprocessor to compensate the output signal of the transmitter; providing the user with a very accurate output signal independent of changing process conditions.

Improved Accuracy

- Reduces maintenance by requiring fewer recalibrations.
- Eliminates the need for a special “high accuracy” transmitter.

A High Span Turndown Ratio

- Reduces spare parts inventory by eliminating the need for a number of different transmitters with intermediate ranges;
- Provides range changing flexibility, reducing the need to replace transmitters to accommodate variations in process operating conditions.

Improved Temperature and Static Pressure Compensation

- Improves the operating accuracy, repeatability, and stability of the transmitter.
- Reduces the maintenance requirements associated with recalibrating the transmitter during changing temperature and static pressure conditions.

Diagnostics

- Alerts the operator quickly of any detected diagnostic conditions;
- Reduces maintenance time associated with startups and troubleshooting.

Write Protection

- Consists of a jumper located on the electronics board that the user can set to allow read and write access, or read only access to device configuration.

Remote Adjustability

- Allows an operator to select the span, zero, damping, linear or square root output, and forward or reverse action accurately from the control room;
- Reduces maintenance time associated with range change or recalibrations;
- Allows an operator to communicate with a transmitter in a hard-to-reach location, or in hazardous area without entering the areas.



Figure 5 3/4 ST 3000 Fieldbus Transmitter

ST 3000 Fieldbus Options

A wide variety of options are available, including:

Lightning Protection - LP

A terminal block with circuitry that protects the transmitter from transient surges induced by nearby lightning strikes.

Mounting Bracket - MB, SB, FB

Available in angle or flat style, and is suitable for either horizontal or vertical mounting on a two-inch pipe or for wall mounting.

Indicating Meter- SM

A local integrated meter option provides an LCD display for digital output and can be configured to display 0 to 100% pressure in selected engineering units as well as device status messages.

ST 3000 Fieldbus Operating Power

The ST 3000 Fieldbus transmitter operates in the range of 9.0 to 32 Vdc @ 20 mA.

Ordering Information

Model Specifications

Refer to the specification sheets listed below for specifications on individual transmitter models.

Differential Pressure

Series 100 34-ST-03-60
Series 900 34-ST-03-65

Gauge/Absolute Pressure

Series 100 34-ST-03-61, 62
Series 900 34-ST-03-66, 67

Flange Mounted Liquid Level

Series 100 34-ST-03-63
Series 900 34-ST-03-68

Remote Diaphragm Seals

Series 100 34-ST-03-64
Series 900 34-ST-03-57

High Temperature GP

34-ST-03-70

Flush Mount Transmitter

34-ST-03-72

Fieldbus Foundation and FOUNDATION are trademarks of the Fieldbus Foundation.

Contact your nearest Honeywell sales office, or

In the U.S.:

Honeywell
Industrial Automation & Control
16404 N. Black Canyon Highway
Phoenix, AZ 85023
1-800-288-7491

In Europe:

Honeywell PACE
1, Avenue du Bourget
B-1140 Brussels, Belgium
[32-2] 728-2111

In Asia:

Honeywell Asia Pacific Inc.
Room 3213-25
Sun Hung Kai Centre
No. 30 Harbour Road
Wanchai, Hong Kong
(852) 2829-8298

In Canada:

The Honeywell Centre
155 Gordon Baker Rd.
North York, Ontario
M2H 3N7
1-800-461-0013

In Latin America:

Honeywell Inc.
480 Sawgrass Corporate Parkway,
Suite 200
Sunrise, FL 33325
(954) 845-2600

In the Pacific:

Honeywell Limited
5 Thomas Holt Drive
North Ryde NSW 2113
Australia
(61 2) 9353 7000

Or, visit Honeywell on the World Wide Web at:
<http://www.honeywell.com>

Specifications are subject to change without notice.

Honeywell

Industrial Automation and Control

Honeywell Inc.
16404 N. Black Canyon Highway
Phoenix, AZ 85023