

## HC900 Hybrid Controller

*When you need more than just discrete control*

### Product Note - Pulse/Frequency/Quadrature (PFQ) Module Model 900TCK-0001

The PFQ Module for the HC900 controller is a multi-function module intended for use with high speed digital pulse generating field devices such as flow meters, gas meters, proximity switches, speed sensors etc. The module provides four input channels that may be configured by the user to perform up to four types of operations by assigning unique function blocks to each channel. A HC900 system will support up to 4 PFQ modules per I/O rack in up to 5 I/O racks. The maximum PFQ channels per HC900 system is (4 channels/module x 4 modules/rack x 5 racks/system = 80 channels). The operations supported by the module and function blocks are detailed as follows:

#### Pulse Counting

With this function the module counts input transitions asynchronously from pulse generating sensors and buffers the total results at speeds faster than the scan rate of the controller function blocks. At the beginning of each function block scan cycle the updated count from the module is passed to the controller. The count value is converted to engineering units by the function block and the accumulated total is presented at the output pin of the function block.

The rate at which the pulses are being accumulated is also calculated and presented on a Rate output pin in Engineering Units per time period. The time period is settable by the user in (Units/hr, min or sec) during configuration. A selection for the time period over which pulses will be accumulated for calculating the average rate output value is also provided. The user should enter a sample time that provides a sufficient quantity of pulses to determine an average rate without over-damping the output results.

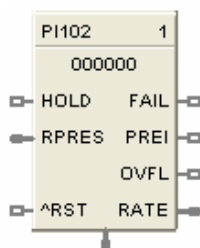

A preset value is included in the function block setup to perform control actions based on the accumulated count. The preset value may be set as a parameter internal to the function block or it may be an input signal connected to the RPREs (Remote Preset) input pin of the function

block. The preset value is entered in engineering units. The value is held in both the function block in EUs and in the input module in pulses. When the pulse count in the module is equal to the preset value, an output transistor on the module is turned ON independent from the function block. When the value in EUs in the function block is equal to preset value, the PREI output pin of the block is turned ON. This is assumed to occur on the next scan following the module control action.

There are two types of Preset output actions available to the user during configuration, 1) Latch preset output and 2) momentary preset output. If latched output is selected, the PREI output pin and the module transistor output will remain ON, pulse accumulation will cease and the pulse rate pin will decline to zero. This state will be latched until a rising edge digital signal is received at the function block Reset input. Following a reset, the outputs (PREI and Transistor) will be turned OFF, the accumulated count/EUs will be set to zero and counting will resume. If Momentary Preset action is selected, when the count and EU values equal the Preset value, the outputs turn ON for one (1) second and immediately the EU value and modules counts are reset to zero and counting resumes. A Preset value of zero will disable the preset function.

A Hold input to the function block will prevent the module from incrementing the accumulated value during the period the hold is active. When hold is turned off the count resumes from its previous value. It should be noted that a hold delay of at least one controller scan cycle will occur between the function block execution and the module action when the hold function is implemented.

If the module is permitted to accumulate counts until its registers are full, an overflow condition will occur in the module and the OVFL and FAIL output pins on the function block will turn ON. To clear the registers and turn the OVFL and FAIL output pins OFF, activate the RST pin.

### Pulse Frequency

This function is used to measure continuous pulses occurring at a frequency that may be scaled to represent a rate value in engineering units. An application example may be a flow meter providing pulses that represent the gallons per hour of material being sensed by the meter, (the higher the measured frequency, the greater the flow rate).

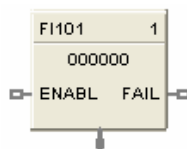

Inputs to this function can be within a frequency range of 10hz to 100Khz and the block output is in user specified engineering units. The user specifies a frequency range that matches the range of the sensor or transmitter being used. An engineering unit span is entered to convert the frequency to engineering units. Under normal operation the output of the function block will not exceed the user specified engineering unit limits, regardless of the value of the input frequency. A Failsafe selection is provided to allow the user to specify an action or output value if the input signal is out of range or if communications between the CPU and the module is interrupted. The failsafe value may be set to exceed the engineering unit limits if desired.

The input of the module is capable of measuring pulses down to a 3microseconds width. To prevent the input from sensing high speed noise along with valid lower speed input frequencies, the user needs to set limits on the minimum pulse width using the Pulse Width Range selection in the function block setup dialog. Set the pulse width and associated frequency span so that the high frequency value is greater than the high end frequency output of the sensor or transmitter. Measured frequencies that are less than or greater than the pulse width frequency limits will be handled as an error condition, turning ON the FAIL pin of the function block and setting the block output to the appropriate failsafe value.

A 1<sup>st</sup> order Filter value in seconds and Bias value in engineering units may be entered by the user. These two selections get applied to the engineering unit value of the function block output.

The Enable input to the function block is optional. If a parameter is connected to the Enable input pin, the block checks for an On state (Logic 1) on the pin before the block will execute. If the Enable pin is unconnected, the default state of the block is enabled.

### Pulse Output

Many applications require a series of pulses produced at specific intervals (a pulse train) to interface to the devices being regulated. The digital outputs of the HC900 PFQ module may be configured to generate a finite quantity of pulses (between 1 and 2<sup>24</sup>) at a user specified frequency between 25Hz and 10kHz. An Off to On transition of a START # PLS input pin on the function block starts the output operation when the block is enabled. The block will complete the pulse train once started. The Start # PLS input pin must turn OFF (Logic 0) before a second pulse train can be started.

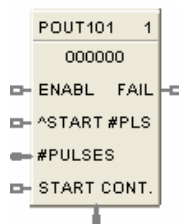

The Enable input to the function block is optional. If a parameter is connected to the Enable input pin, the block checks for an On state (Logic 1) on the pin before the block will execute. If the Enable pin is unconnected, the default state of the block is enabled.

A continuous pulse output selection at the specified frequency is also available. When the block is enabled and an On state (Logic 1) exists on the CONT input pin of the function block, the module will generate an output pulse continuously. Once in the continuous mode of operation, if the inputs to either the ENABL or CONT input pins turn Off (logic 0), the output stops pulsing. If the ENABL or CONT input pin subsequently turns back ON, the continuous mode will restart automatically.

The output pin at the bottom of the function block provides indication of the pulses remaining for long output trains. The value will be zero for continuous output operation.

A failsafe selection is available for the block in the event that communications is interrupted between the controller and the output module. Choices are to continue the last requested pulse output operation or turn the output Off immediately. A FAIL output pin on the function block will turn ON to indicate a fault condition.

### Quadrature Inputs

The Quadrature input function uses two digital inputs, Inputs A and B (inputs 1 & 2 of the module), to determine the direction of movement, speed of movement and the position of moving devices. A digital encoder is typically used to convert the process movement into digital signals that can be measured by the HC900 PFQ module. Digital encoders are available in a variety of configurations to measure linear motion and rotary motion in a multitude of mechanical orientations. Electrically, encoders offer different output pulses per revolution to allow for higher or lower resolution of the measured variable and they may use single-ended or differential voltage or current outputs. Differential outputs are sometimes applied over longer distances or in electrically noisy environments. In addition to the two inputs used to measure changes, a third input, the Index input, is provided to identify the Home or zero count position of the device being measured. From the Home (Index) position, the measured value can increase or decrease based on the direction of process travel.

A typical rotary digital encoder is pictured below.



Before connecting an encoder to the HC900 module, verify if the measured electrical signal will be single ended or differential. Switches are provided on the module to select single ended or differential inputs for the two measurement inputs and the Index input. A 5Vdc power supply output capable of supplying up to 500 mA is provided on the HC900 module to power encoders. External power supplies may also be used for single ended inputs up to 24Vdc. Note the maximum input voltage the module can handle is different for single ended signals vs. differential signals. Encoders that provide current switching outputs may require shunt resistors across the outputs to interface with the HC900 module. The load provided by the module is ~25K ohms for single ended inputs and ~5K for differential inputs. The following chart indicates the voltage levels of single ended and differential inputs:

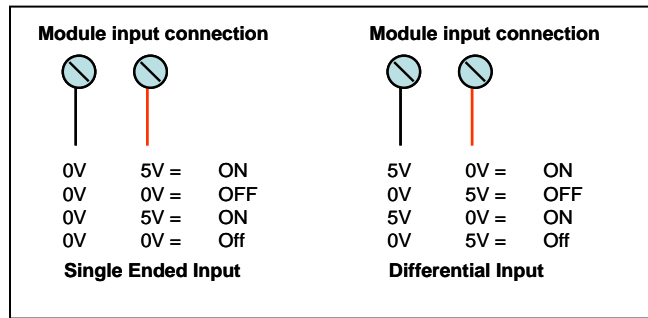

In addition to the power and signal connections between the PFQ module and encoder, a cable validity input is provided on the PFQ module to confirm that the Quadrature sensor cable is in tact and connected to the sensor. If the encoder does not provide this input the user must complete the circuit by placing a jumper across the input terminals of the PFQ module. If this circuit is not complete the CDIS output pin of the function block will turn ON and the quadrature function will not operate.

A Quadrature function block is provided in the HC900 controller to support applications using this measurement technology. Only one quadrature input is available per PFQ module and inputs 1 and 2 are assigned to this function. Inputs 3 and 4 of the module may be used for other measurements using the previously described block types.

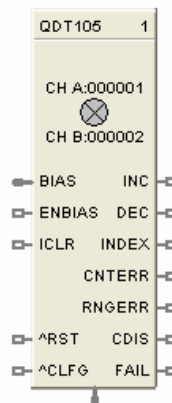

The output value of a Quadrature function block is provided in user specified engineering units. When setting up a Quadrature input channel the user specifies the number of pulses per engineering unit and the upper and lower range limits in engineering units. For non-zero based engineering unit spans, i.e. -150 to +150, the zero counts resulting from a Reset input (RST) or Index input to the module would cause the output to indicate the low end of span (-150). If the user wishes to have a zero center range with zero counts equal to zero output, a bias of +150 would need to be input to the bias input of the function block. If no connection is made to the ENBIAS input, the default state is enabled. To deactivate the Bias input, the optional ENBIAS input must be OFF (Logic 0). Input counts would then increment or decrement the output value over the (-150 to 150) span. Values outside this span limits are held at the limits and presented as a range error by turning ON the RNGERR output pin of the function block. The Increment

(INC) and decrement (DEC) output pins would continue to indicate the direction of movement while an out of range condition exists.

A Mode selection is provided for the function block to allow the user to choose the type of input sense characteristics desired. The choices provided are as follows:

X1 Mode = Signals A and B determine count and direction. When the A pulse leads the B pulse (A pulse transitions high while the B signal is low), the counter increments on the raising edge of A. When the B pulse leads the A pulse (B pulse transitions high while A signal is low), the counter decrements on the falling edge of A. See the figure below:

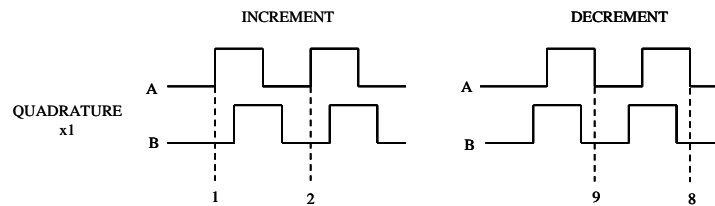

X2 Mode = This quadrature input mode provides a 2X increase in resolution by counting both the rising and falling edges of the A input. If channel A dithers on an edge of a single pulse, the counter will increment or decrement only when the channel B has changed state. If the B input does not change state, no change will be sensed.

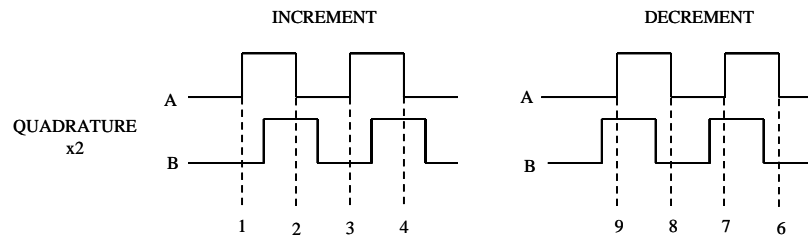

X4 Mode = This quadrature input mode provides a 4X increase in resolution by counting both the rising and falling edges of both the A and B inputs. This eliminates errors caused by dithering.

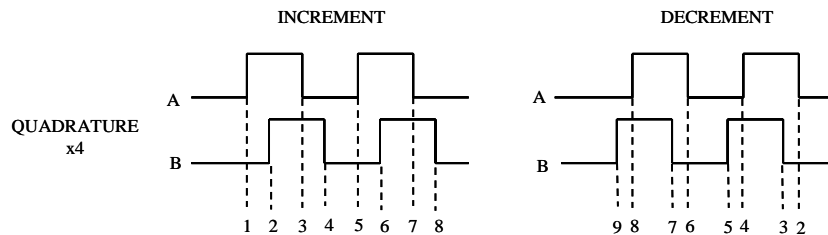

Resetting the Quadrature function sets the count value to zero, clears any overflow or underflow conditions and sets the output value to the low end of span, plus the BIAS input value. Reset action may be initiated by an OFF to ON transition of the RST input pin of the function block or

via the Index input on the module in combination with the ICLR input pin of the function block. To use the Index input, when the ICLR input of the function block is ON (logic 1), an OFF to ON transition of the Index input to the module will reset the Quadrature function. Once reset via the Index input, the ICLR input must turn OFF and back ON before a second assertion of the Index input will be accepted. An INDEX output pin on the function block turns ON to indicate when the module Index input is ON.

The failsafe selections available with the Quadrature input are similar to other input types. The output value resulting from the user specified failsafe action will occur if communications between the controller and the input module fails or if a problem is detected in the input module.

If overflow or underflow conditions are detected in the module counter, the CNTERR output pin of the module to turn ON and counting will cease. This condition may be corrected by causing an Off to ON transition of the CLFG (Clear Flag) input to turn the counter fault pin off, then reversing the direction of the process to reduce the count, or by a reset action as described above. The reverse direction with the CLFG assertion acknowledges the counter error and allows the process to recover from its current state. The reset action will reset the counter to zero and cause the output of the block to go to the low end of scale, plus the BIAS value.